



QUALITY & SERVICE
MAKE THE "DIFF"

Next Generation Differential Control System

Series 67D

Instruction Manual

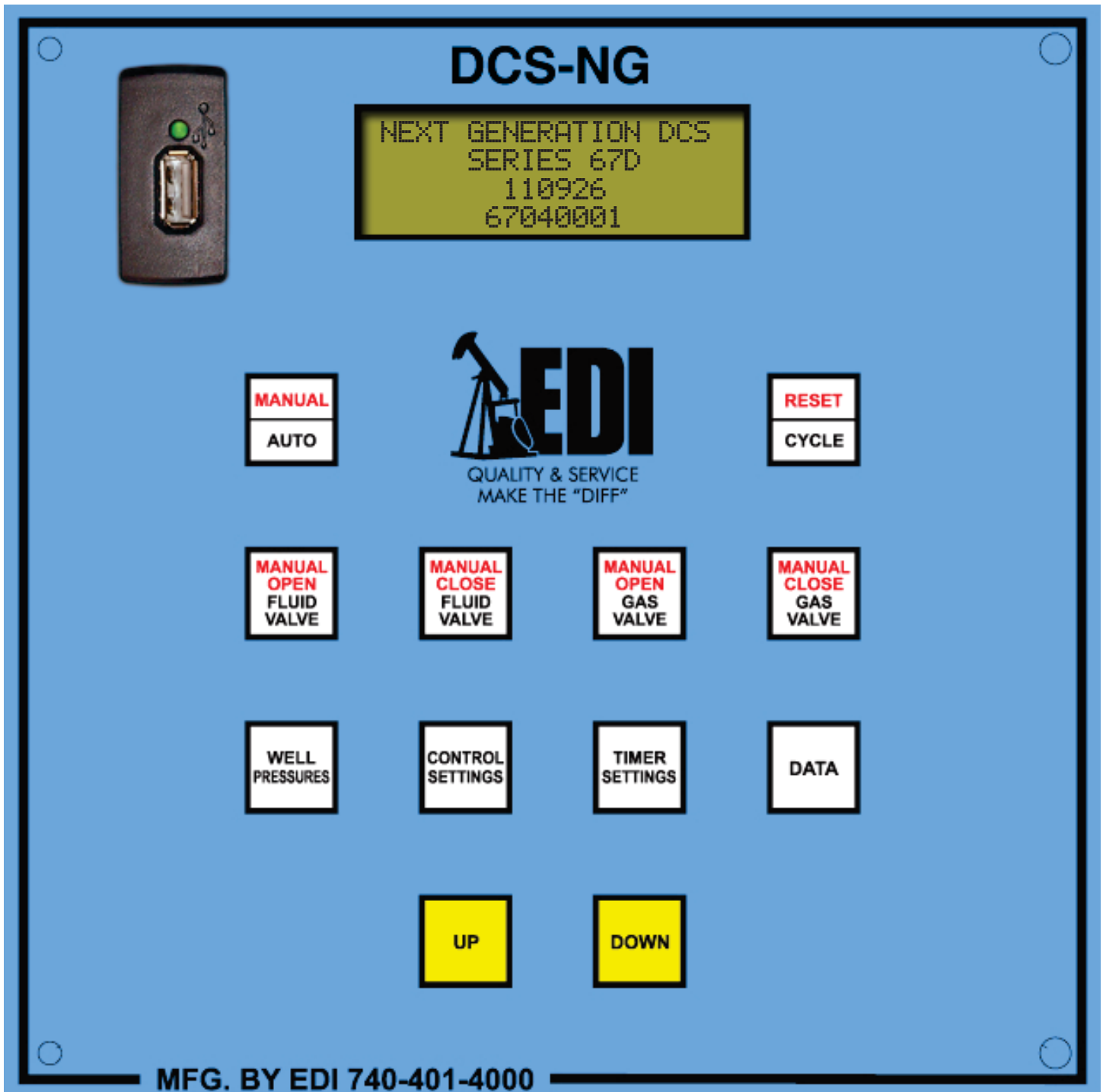
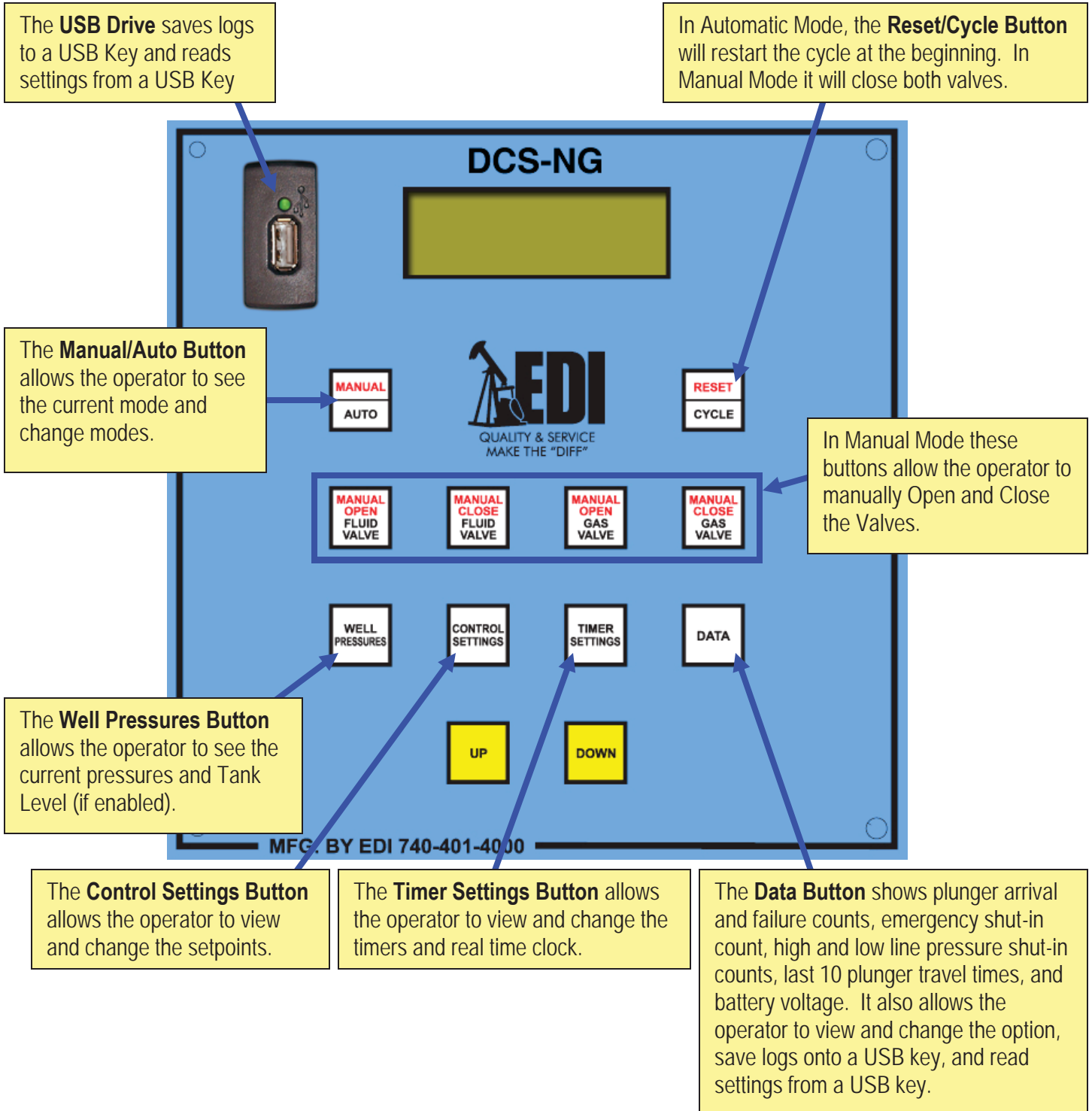

Table of Contents

The Controller	1
The Main Screen.....	2
Switching Modes	2
Reset/Cycle Button	3
Manually Opening/Closing the Valves.....	3
Viewing the Well Pressures	4
Setting the Control Settings	4
Viewing Data	6
Changing the Option	7
Saving Logs to a USB Key.....	8
Reading Settings from a USB Key	9
Setting the Timer Settings.....	10
Setting the Date and Time	12
Wiring Diagrams.....	13
USB Key Requirements	13
Changing Communication Settings	14
Technical Specifications.....	16
Starting Setpoints.....	17

The Controller



The Main Screen

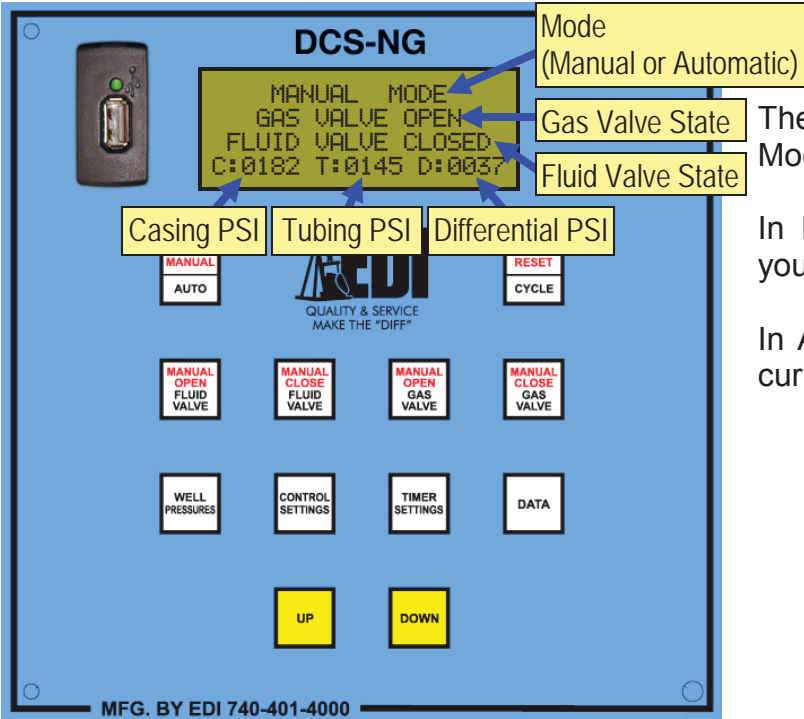

The main screen shows Automatic or Manual Mode and shows pressures on the bottom.

In Manual Mode, shown on the left, it shows your Gas and Fluid Valve States.

In Automatic Mode, shown below, it shows the current task, and its timer.



Switching Modes

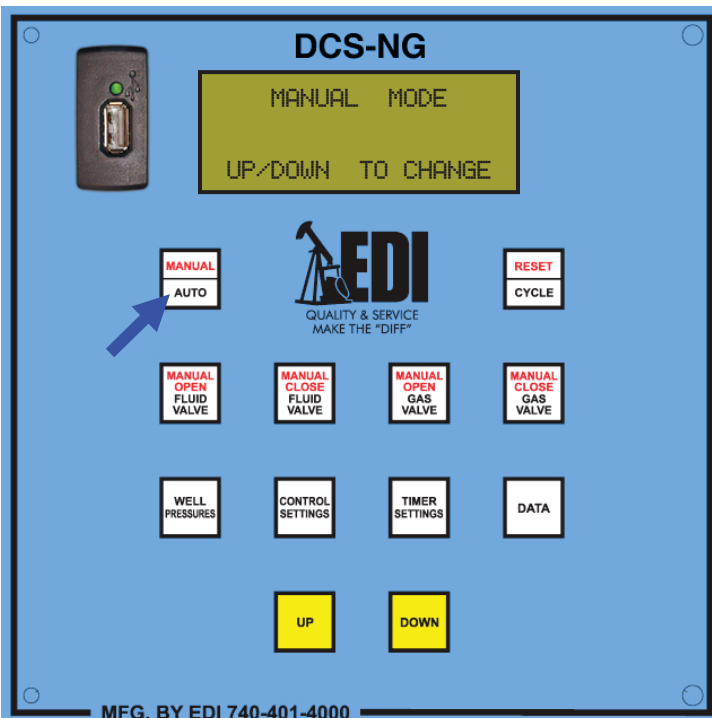

To switch between Automatic Mode and Manual Mode, press the Manual/Auto button. While holding the Manual/Auto button, press the Up or Down button to switch between modes, release the Manual/Auto button to apply the change.

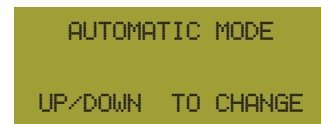

Reset/Cycle Button

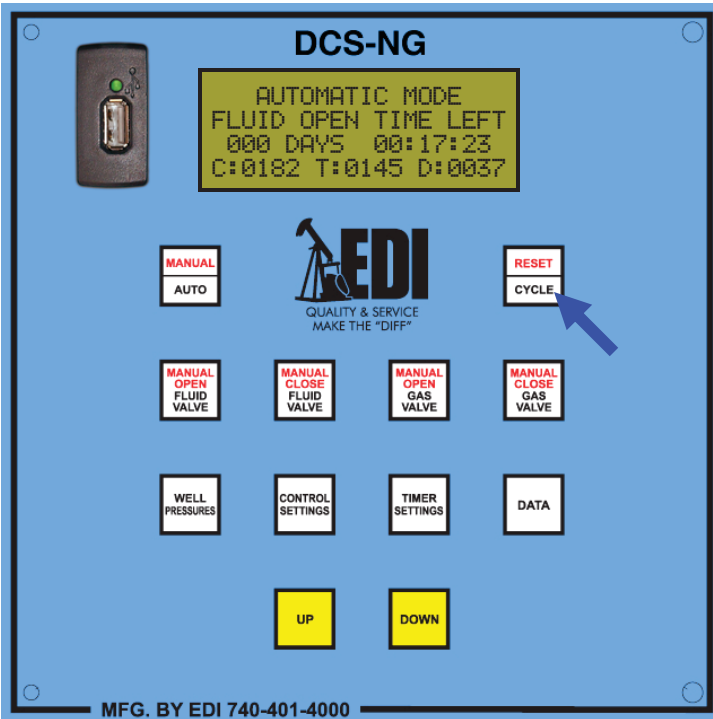

The Reset/Cycle button resets the system to the start point of the system cycle. In Automatic Mode, this button closes both valves, cancels any running timers, and starts at the beginning sequence of the cycle. In Manual Mode, this button closes both valves and cancels any time periods.

Manually Opening and Closing the Valves

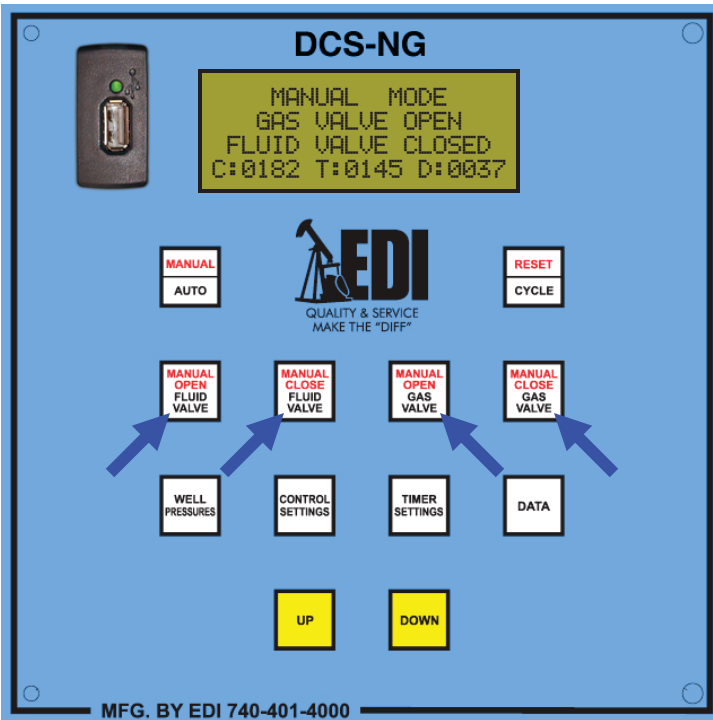

If the DCS is in Manual Mode, the buttons pointed out on the left allow the operator to manually Open and Close the Gas and Fluid Valves.

In Option 4, these buttons are active in Automatic Mode to allow the operator to manually change the active cycle.

To Open the Head Gas Valve in Manual Mode, Hold the Up button while pressing the Open Gas Valve button.

To Close the Head Gas Valve in Manual Mode, Hold the Up button while pressing the Close Gas Valve button.

Viewing the Well Pressures

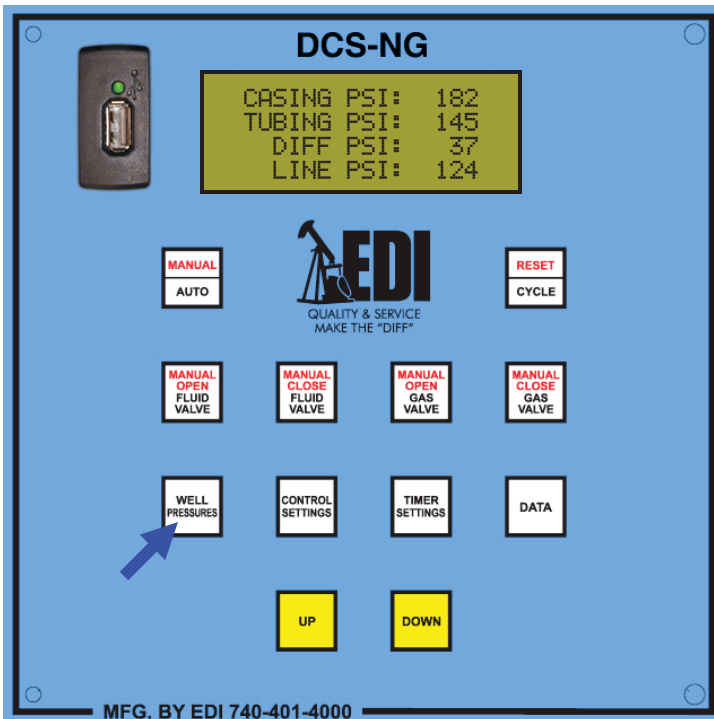

The operator may at any time press the Well Pressures button to view the current well pressures and Tank Level (if enabled).

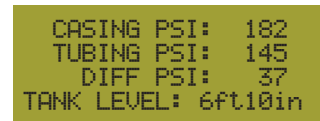

Setting the Control Settings

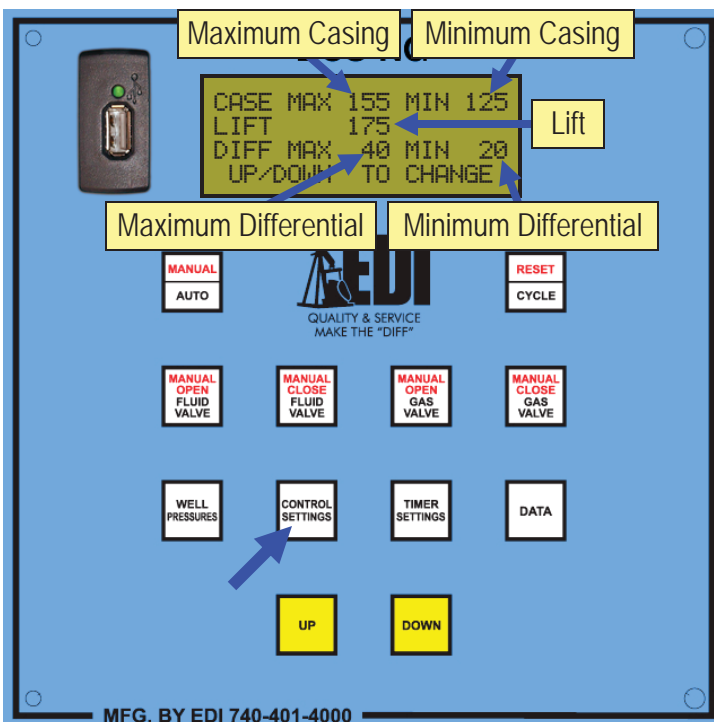

Press and release the Control Settings button to scroll through a summary of the main Control Settings, a summary of the Line Pressure Settings (if enabled), and the Maximum Tank Level setting (if enabled).

While on a summary screen, shown on the left and below, press Up or Down to begin changing those settings.

While on a setting screen, use the Up and Down buttons to adjust the setting, then release the Control Settings button. **Press the Control Settings button again to see the next setting.**

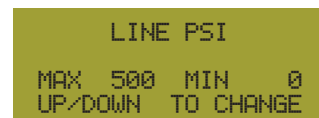

Next Generation DCS Instruction Manual

Setting the Control Settings (cont'd)

MAX CASE
155 PSI

Maximum Casing PSI establishes the maximum limit of the Casing Pressure during gas sales. When this pressure setting is reached, the Gas Discharge valve is opened until the Casing Pressure falls to the Minimum Casing PSI setting.

MIN CASE
125 PSI

Minimum Casing PSI establishes the minimum limit of the Casing Pressure during gas sales. When this pressure setting is reached, the Gas Discharge valve is closed, until the Casing Pressure builds to the Maximum Casing PSI setting.

LIFT
175 PSI

Lift PSI sets the amount of Casing Pressure required to lift the maximum amount of fluid as determined by the Maximum Differential PSI setting.

MAX DIFF
40 PSI

The **Max Diff** and the **Min Diff** control the fluid load in the tubing string. The **Max Diff** determines the maximum fluid load that will be allowed to accumulate in the tubing string. The **Min Diff** determines the minimum fluid load allowed to accumulate before the plunger runs.

MIN DIFF
20 PSI

During gas sells, when the differential pressure reaches the **Min Diff** setting, if the casing pressure is at or above the **Lift** setting a plunger run starts immediately.

If the casing pressure is below the **Lift** setting, when the differential pressure reaches the **Min Diff** setting, the gas valve will remain open until the differential pressure reaches the **Max Diff** setting. Once the differential pressure equals the **Max Diff** setting the well will shut in until the casing pressure builds to equal the **Lift** setting, then the system starts a plunger run.

SET MAX LINE PSI
MAX LINE 500 PSI
UP/DOWN TO CHANGE

Maximum Line PSI (if enabled) sets the maximum amount of Line Pressure allowed. When the Line Pressure exceeds this setting, the controller will close both valves until the pressure falls below this setting.

SET MIN LINE PSI
MIN LINE 0 PSI
UP/DOWN TO CHANGE

Minimum Line PSI (if enabled) sets the minimum amount of Line Pressure required. When the Line Pressure falls below this setting, the controller will close both valves until the pressure rises above this setting.

SET MAX TANK LEVEL
9ft 6in
UP/DOWN TO CHANGE

Maximum Tank Level: (if enabled) This control sets the maximum amount of fluid in the tank. When this level is reached, the controller will close both valves. When the tank level falls below the Maximum Tank Level set point, normal operation will resume.

Viewing Data

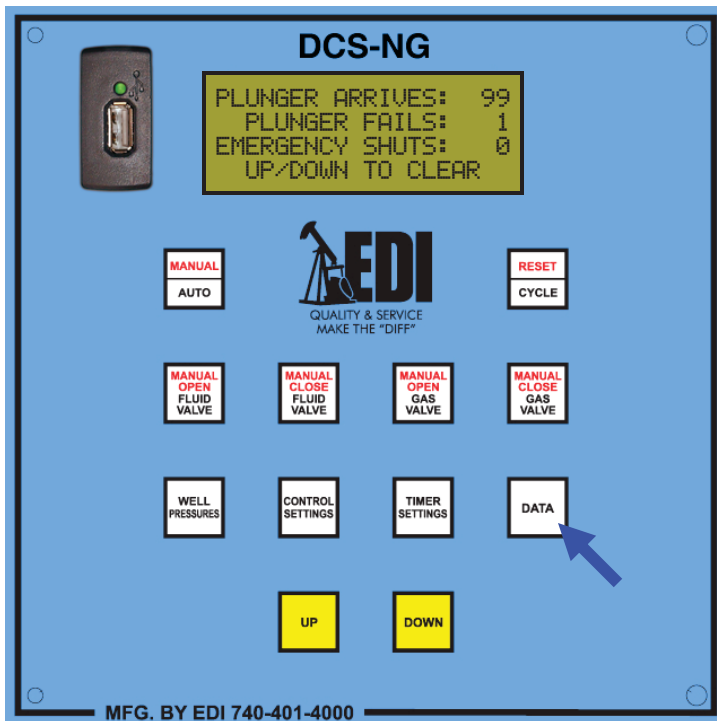

Use the Data button to view data, such as, Plunger Arrivals, Plunger Failures, Plunger Travel Times, Emergency Shut-Ins, and Battery Voltage. **Release the Data button, and press it again to advance to the next screen.**

```

PLUNGER ARRIVES: 99
PLUNGER FAILS: 1
EMERGENCY SHUTS: 0
UP/DOWN TO CLEAR
    
```

The first screen shows a count of the number of Plunger Arrivals, Plunger Failures, and Emergency Shut-Ins. Press the Up or Down button to clear these counts.

```

HIGH LINE COUNT: 22
LOW LINE COUNT: 14
UP/DOWN TO CLEAR
    
```

If line pressure is enabled, the next screen will display the High Line Pressure and Low Line Pressure Shut-In counts. Press the Up or Down button to clear these counts.

```

PLUNGER TRAVEL TIMES
01 ARRIVED 00:10:17
02 FAILED 00:30:00
UP/DOWN TO VIEW MORE
    
```

Plunger Travel Times: This screen shows the 10 most recent Plunger Travel Times, and their statuses (Arrived or Failed). Press the Up or Down button to scroll through these results.

```

BATTERY VOLTAGE
12.83v
CHARGING
    
```

Battery Voltage: This screen shows the current battery voltage and charging status.

```

CLOSE VALVE ON
PLUNGER ARRIVE
OFF
UP/DOWN TO CHANGE
    
```

Close Valve on Plunger Arrival: (Option 5*) This setting specifies if the controller will close the Gas Valve when the plunger arrives.

* Refer to Page 7 for an explanation of the options

Changing the Option

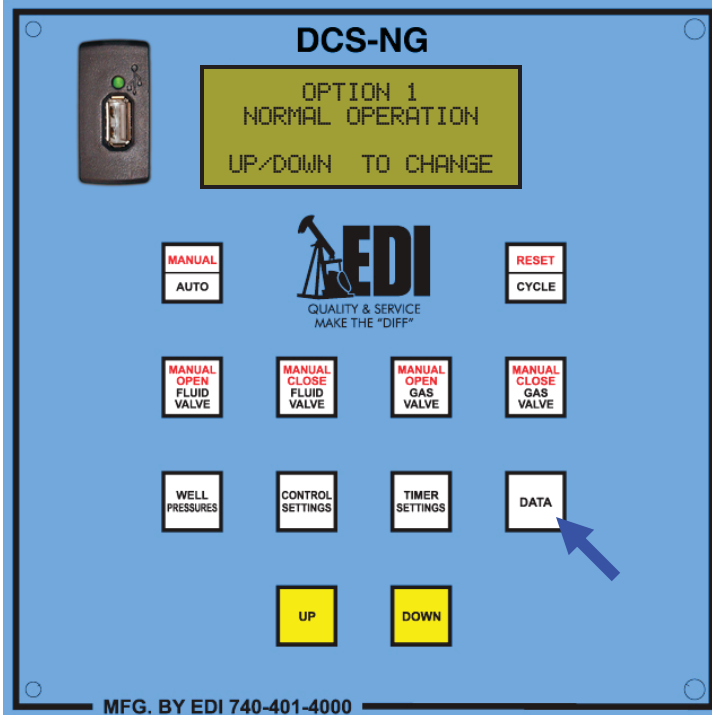

The Option can be changed via the Data button. Scroll through the screens on the Data button, **by pressing and releasing the Data button**, the Option screen is reached. Use the Up or Down buttons to change the option.

OPTION 1
NORMAL OPERATION
UP/DOWN TO CHANGE

Option 1: Normal Differential Operation
Shut time starts **after** the plunger runs.

OPTION 2
SALE GAS AFTER
PLUNGER ARRIVAL
UP/DOWN TO CHANGE

Option 2: Differential Operation
Shut time starts **before** the plunger runs.

OPTION 3
OPTION 2 & HEAD GAS
USES GAS VALVE
UP/DOWN TO CHANGE

Option 3: Differential Operation
Option 3 is based on Option 2, but opens the regular Gas Valve for Head Gas Time. Option 3 also opens an Plunger Release Valve (optional) for 1 minute during Shut Time.

OPTION 4
TWO VALVE
TIMER SEQUENCE
UP/DOWN TO CHANGE

Option 4: Two Valve Timer Operation
This option allows the operator to control the well with full timer capabilities. To setup single valve timer operation, set the Fluid Valve Open Time **or** the Gas Valve Open Time to 0.

OPTION 5
HI/LO
GAS VALVE CONTROL
UP/DOWN TO CHANGE

Option 5: Single Valve High-Low Pressure Operation
This option allows the operator to cycle the well between the Max Casing and Min Casing set points, using only the Gas Valve.

Saving Logs to a USB Key

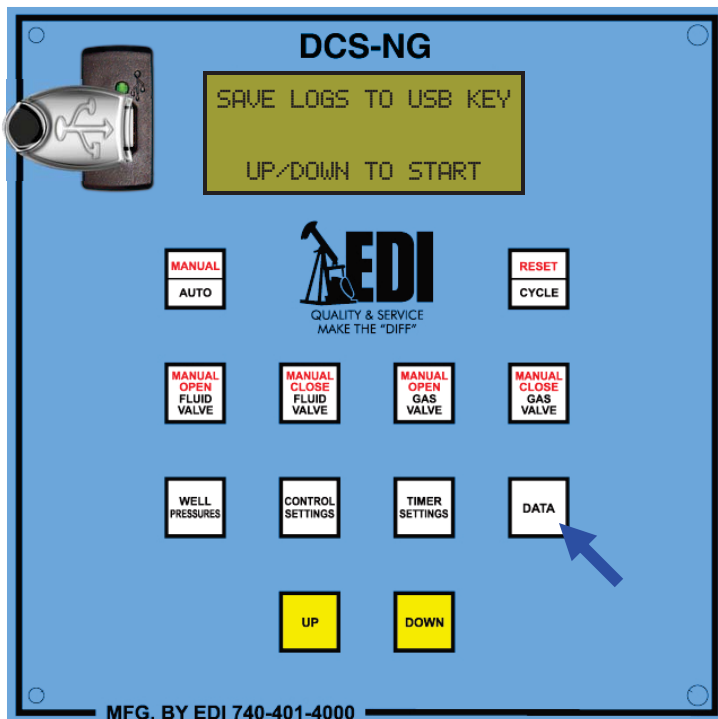

The logs can be saved to a USB key via the Data button.

Scroll through the screens on the Data button, **by pressing and releasing the Data button**, until the screen that says “Save Logs to USB Key” is reached, then press the Up or Down button to begin.

SAVE LOGS TO USB KEY
PLEASE WAIT...

Wait while the controller attempts to establish communication with the USB port.

SAVE LOGS TO USB KEY
PLEASE INSERT DRIVE!
UP/DOWN TO CANCEL

If you have not already done so, insert the USB key when prompted. At this screen, the Up or Down button may be pressed to cancel the operation.

SAVE LOGS TO USB KEY
PLEASE WAIT...
SAVING EVENT LOGS

The controller will begin saving logs onto the USB key.

SAVE LOGS TO USB KEY
PLEASE WAIT...
SAVING INTERVAL LOGS

Do not remove the USB key until the operation is complete!

SAVE LOGS TO USB KEY
OPERATION COMPLETE!

When the operation is completed successfully, the screen will read “Operation complete!”

Please refer to *USB Key Requirements* on Page 13 for information on which USB Keys are compatible with the DCS-NG.

Reading Settings from a USB Key

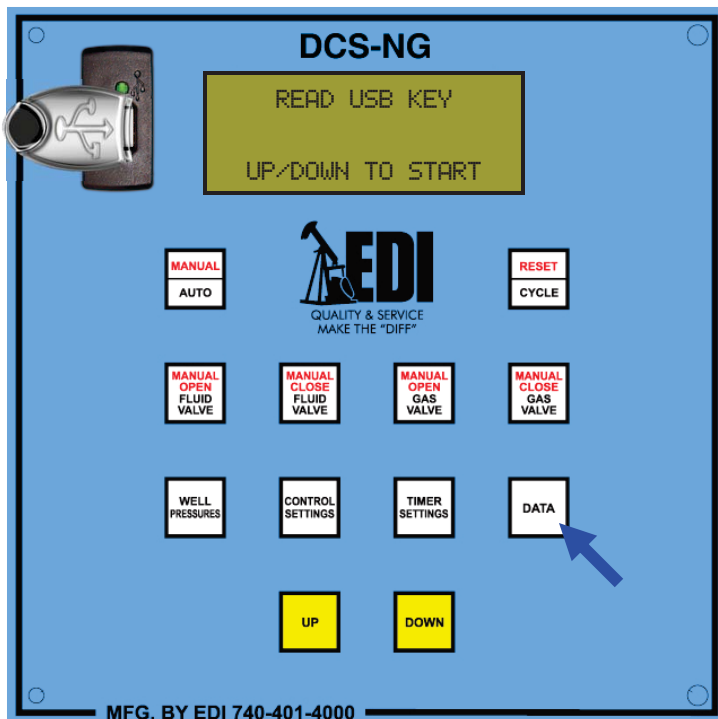

The settings can be read from a USB key via the Data button. DTRACK-NG can be used to Save the Settings to a USB Key.

Then scroll through the screens on the Data button, **by pressing and releasing the Data button**, until the screen that says “Read USB Key” is reached, then press the Up or Down button to begin.

READ USB KEY
PLEASE WAIT...

Wait while the controller attempts to establish communication with the USB port.

READ USB KEY
PLEASE INSERT DRIVE!
UP/DOWN TO CANCEL

If you have not already done so, insert the USB key when prompted. At this screen, the Up or Down button may be pressed to cancel the operation.

READ USB KEY
PLEASE WAIT...
READING SETTINGS...

The controller will begin reading settings from the USB key.
Do not remove the USB key until the operation is complete!

READ USB KEY
OPERATION COMPLETE!

When the operation is completed successfully, the screen will read “Operation complete!”

Please refer to *USB Key Requirements* on Page 13 for information on which USB Keys are compatible with the DCS-NG.

Setting the Timer Settings

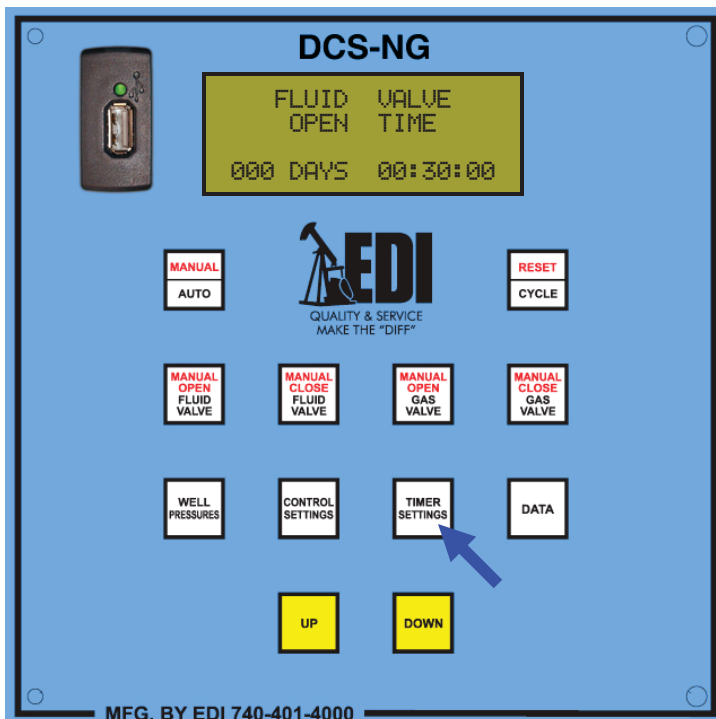

Press and hold the Timer Settings button to set the timer settings. Use the Up and Down buttons to change the timers. **Release the Timer Settings button, and press it again to advance to the next timer.**

Unless otherwise noted, the maximum value for all timers is 7 days 23 hours 59 minutes.



Fluid Valve Open Time: (Options 1, 2, 3 & 4*) This timer sets the amount of time the fluid valve will remain open and wait for the plunger to arrive. If the plunger does not arrive within this amount of time, it is considered a plunger failure.



Fluid Valve Shut Time: (Options 1, 2 & 3*) This timer sets the amount of time the fluid valve will remain shut, following a plunger arrival, allowing the plunger to fall back to the bottom of the tubing.



Recovery Time: (Options 1, 2 & 3*) This timer allows for additional shut time, after the plunger has failed to surface, if the actual differential pressure is greater than the Maximum Differential set point.



Purge Time: (Options 1, 2 & 3*) This timer sets the amount of additional open time, after the plunger has surfaced. (Maximum Value: 18 hours)

* Refer to Page 7 for an explanation of the options

Setting the Timer Settings (cont'd)

```
HEAD GAS TIME
000 DAYS 00:30:00
```

Head Gas Time: (Options 1, 2 & 3*) This timer opens the Head Gas Valve to sell the head gas before opening the fluid valve. If the plunger arrives during this time, it will count as a Plunger Arrival. If the plunger does not arrive during this time, it will open the fluid valve and run Fluid Open Time to finish the plunger cycle into the tank.

```
DIFF DELAY
000 DAYS 00:10:00
```

Differential Delay: (Options 2 & 3*) This timer sets the amount of time for mandatory gas sales before the system recognizes differential.

```
SHUT TIME
000 DAYS 00:10:00
```

Shut Time: (Option 4*) This timer sets the amount of time the fluid valve will remain shut, following a plunger arrival, allowing plunger to fall back to the bottom of the tubing.

```
GAS VALVE
OPEN TIME
000 DAYS 01:00:00
```

Gas Valve Open Time: (Option 4*) This timer sets the amount of time the gas valve will remain open.

```
AFTERFLOW TIME
000 DAYS 00:01:00
```

Afterflow Time: (Option 4*) This timer sets the amount of additional open time to sell gas, after the plunger has surfaced.

```
FALL TIME
000 DAYS 00:01:00
```

Fall Time: (Option 4*) This timer sets the amount of additional shut time that will occur after the plunger has surfaced allowing the plunger to reach bottom.

```
LINE PRESSURE DELAY
000 DAYS 00:00:30
```

Line Pressure Delay: This timer only applies when line pressure is enabled and sets the amount of additional shut time that will occur after a line pressure shut-in. (Maximum Value: 18 hours)

```
RECORD LOG INTERVAL
000 DAYS 00:05:00
```

Log Interval: This timer sets the time interval at which the device will record a log of the casing, tubing, and differential pressures. If enabled, it will also record the line pressure. Setting the time interval to 0 minutes will disable the interval log.

* Refer to Page 7 for an explanation of the options

Setting the Date and Time

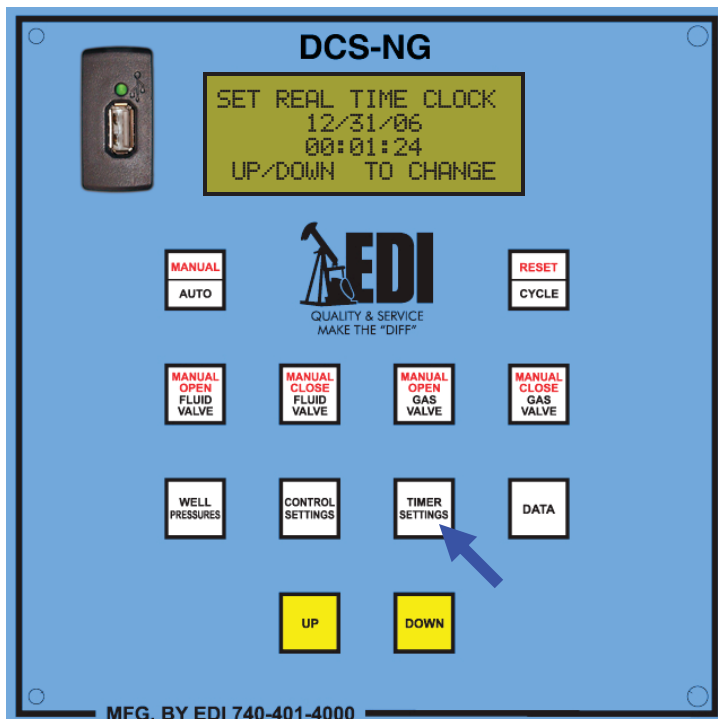

The Real Time Clock can be set via the Timer Settings button. Scroll through the screens on the Timer Settings button, **by pressing and releasing the Timer Settings button**, until the Set Real Time Clock screen is reached. Press the Up or Down buttons to begin setting the clock.

Use the Up and Down buttons to change the displayed part of the date and time, then release the Timer Settings button. **Press the Timer Settings button again to advance to the next screen.**

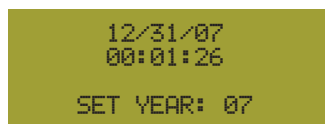

Set the year.

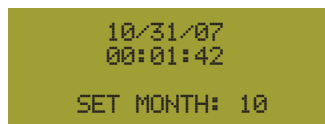

Set the month.

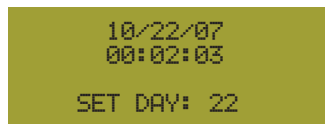

Set the day.

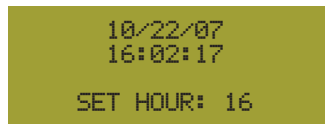

Set the hour.



Set the minutes.

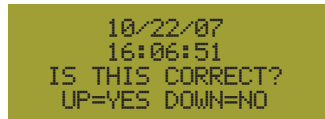

Verify that the date and time are correct. Press the Up button if this is correct. Press the Down button to start over.

Wiring Diagrams

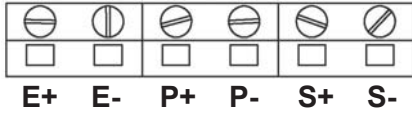

E	Emergency Well Shut-In Input
P	Plunger Sensor Input
S	Solar Panel Input

Communications*

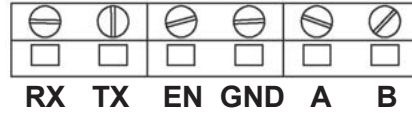

RS-232		RS-485
RX	Receive	A
TX	Transmit	B
EN	Enable	
GND	Ground	

Wired Eagle Communication*



DCS-NG		<—>	Eagle Unit	
RX	Receive	Red	L3	Transmit
TX	Transmit	White	L4	Receive
EN	Enable	Braided	L5	CMSW
GND	Ground	Black	L6	Ground

Jumper to PG

Radio Communication*

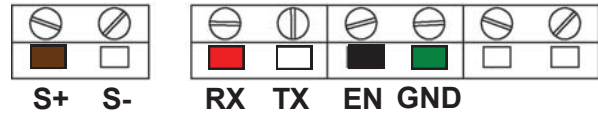

RX	Receive	Red
TX	Transmit	White
EN	Enable	Black
GND	Ground	Green
S+	+12v	Brown

*** Surge Suppression must be used on the Master Device!**

USB Key Requirements

There are limitations to the type of USB Key which can be addressed by the DCS-NG. It is recommended that you obtain an EDI USB Key for use with the DCS-NG. Drives that do not meet the following requirements are not supported and may be unreliable and/or cause data loss.

- Maximum Drive Capacity:** 16 GB (16000 MB)
- Supported File Systems:** FAT / FAT16
FAT32
- Maximum Cluster Size:** 32KB

To check the compatibility of USB Keys and easily re-format them (if necessary), download and run the USB Drive Compatibility Checker from the Downloads section at ediplungerlift.com.

Changing Communication Settings

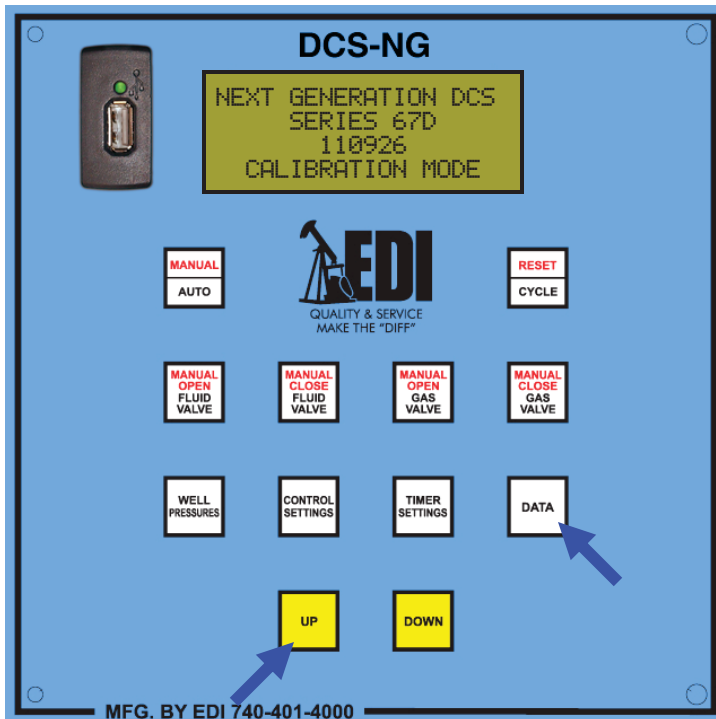

Turn off the controller using the power switch on the back of the circuit board. While holding the Up button, turn the controller back on. Once the startup screen appears, release the Up button. If the startup screen does not say “Calibration Mode” at the bottom, try again.

```
CALIBRATION MODE
PRESS DATA TO
CHANGE SETTINGS
C:0182 T:0145 D:0037
```

Once the board is finished with the startup sequence, the screen should say Calibration Mode at the top of the screen.

```
COMMUNICATION SETUP
UP/DOWN TO CHANGE
```

Press and release the Data button until the screen reads Communication Setup. While holding the Data button, press either the Up or Down button.

```
UNIT ID (1-247): 1
```

The first screen will allow the modbus device id to be changed. While holding the Data button, use the Up and Down buttons to change the id. The original factory setting is 1. By default, this setting should be 1 if used with an Eagle device, and 2 if used with a Fisher device.

```
RS-232 BAUD RATE
9600
```

The next screen will allow the RS-232/RS-485 baud rate to be changed. While holding the Data button, use the Up and Down buttons to change the baud rate. The original factory setting is 9600. If the DCS is connected to another device, the baud rate should be the same on both devices.

Changing Communication Settings (cont'd)

RS-232 INTERVAL
ALWAYS ON

The next screen will allow the RS-232 Interval Timer to be changed. This is mainly designed for use with radios, and specifies how often the RS-232 Port will be turned on to communicate.

- It will turn on 30 seconds early to compensate for possible time differences and ensure that the radio is properly initialized before the other device begins to attempt communicating. For example, if set to 10 minutes, it will turn on every 10 minutes at 12:09:30, 12:19:30, etc.
- Setting this to Always On will keep the RS-232 Port on continuously.
- Setting this to Disabled will keep the RS-232 Port turned off continuously.
- If this is set to a number of minutes (instead of Always On or Disabled), the RS-232 Port will turn off 10 seconds after communication has ended.

While holding the Data button, use the Up and Down buttons to change the setting. The original factory setting is Always On.

RS-232 SLEEP TIMER
DISABLED

The next screen will allow the RS-232 Sleep Timer to be changed. This is mainly designed for use with radios, and specifies how long the RS-232 Port will wait for valid communication before turning off.

- For example, if set to 5 minutes, it will turn off 5 minutes after being turned on, if there is no valid communication.
- This timer is disabled and not used if the RS-232 Interval Timer is set to Always On or Disabled.
- Setting this to Disabled or the same number of minutes as the RS-232 Interval Timer will keep the RS-232 Port on until after valid communication is received. In other words, if valid communication is never received, the RS-232 Port will remain on continuously.

While holding the Data button, use the Up and Down buttons to change the setting. The original factory setting is Disabled.

*** ERASE LOGS ***
UP/DOWN TO CLEAR

The next screen will allow the logs to be erased. While holding the Data button, use the Up or Down button to erase the logs. This will clear both event and interval logs. When the logs have been cleared, the screen will read "Logs Cleared!"

Note: There is no need to clear the logs to allow space for more logs. When the device reaches its maximum number of logs, it will overwrite the oldest logs with new logs.

*** ERASE LOGS ***
LOGS CLEARED!

Technical Specifications

MEMORY

128KB EEPROM Memory
Stores all settings, 2000 Event Logs and 2000 Interval Logs

COMMUNICATIONS

RS-232 or RS-485 is Available
Protocol: Modbus Slave
Has Interval and Sleep Timers to conserve power when using radios
Optional Radio Units come with 900 MHz Radio pre-installed
USB Drive on front allows logs to be saved to a USB Key

POWER

Operating Voltage: 10.5 to 20 VDC
Battery: 12V 9Ahr
Typical Current Draw: 32mA
Battery Life without Recharge:
2 valve actions per hour: Approx. 6.5 days
Solar Panel: 10W
Radio Unit Solar Panel: 20W (with Solar Charging Regulator)

LCD SCREEN

4 line x 20 Character LCD Screen
Automatically enters sleep mode to save power

INPUTS

Casing Pressure (0-2000 psig)
Tubing Pressure (0-2000 psig)
Optional: Line Pressure (0-2000 psig) or Tank Level (0-5 psig)
Input Range: 0-5 VDC
Supply Voltage: 5VDC or 12VDC
Higher pressure ranges available

WEIGHT

22.4 lbs.
Radio Unit: 21.6 lbs.

ENVIRONMENTAL

Operating Temperature: -30°C to 85°C (-22°F to 185°F)
Operating Humidity: 5 to 95%, non-condensing

ENCLOSURE

Weatherproof Painted Steel Enclosure
UL Types 12 & 13
CSA Type 12
NEMA Types 12 & 13
Dimensions: 10" H x 10" W x 6" D

Radio Unit

Weatherproof Fiberglass Enclosure
UL Types 1, 2, 3, 4, 4X, 12 & 13
CSA Types 1, 2, 3, 3R, 4, 4X, 12 & 13
NEMA Types 1, 2, 3, 3R, 4, 4X, 12 & 13
Dimensions: 14.13" H x 12.26" W x 6.13" D

Starting Setpoints

LIFT PSI = Rock Pressure x 0.75
MAX CASE = Rock Pressure x 0.75
MIN CASE = Rock Pressure x 0.5
MAX DIFF = LIFT PSI x 0.33
MIN DIFF = MAX DIFF x 0.5

Lifting against line pressure?

MAX DIFF = MAX DIFF - LINE PSI
MIN DIFF = MAX DIFF x 0.5

Open Time: 5 min per 1000 ft.
Shut Time: 5 min per 1000 ft.

*With the proper lift pressure and the proper fluid load,
the plunger should travel 1 min per 1000 ft.*

NOTE: Settings will vary depending on well conditions.

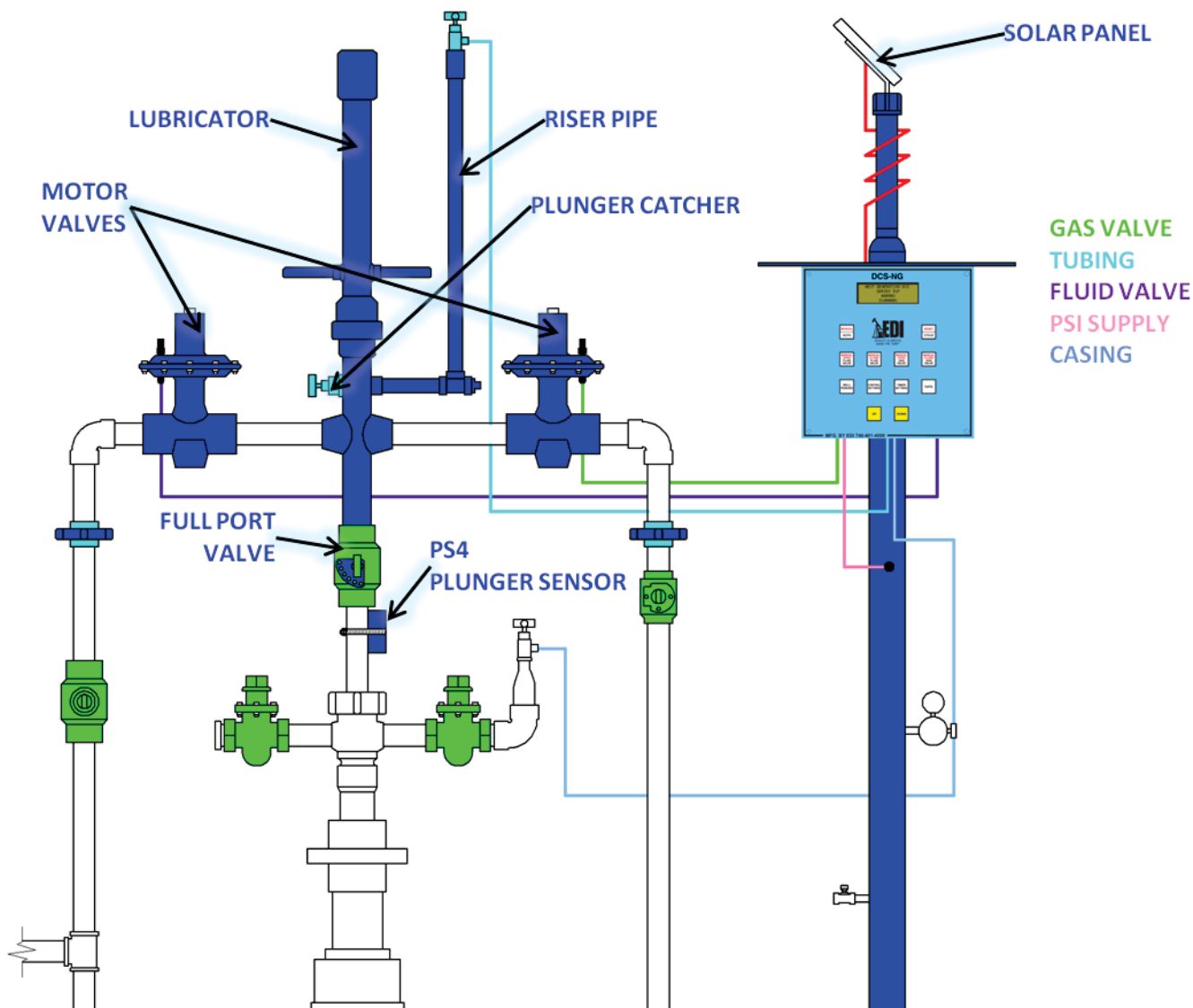



**QUALITY & SERVICE
MAKE THE "DIFF"**

Electronic Design for Industry
100 Ayers Blvd.
Belpre, OH 45714
(740) 401-4000
www.ediplungerlift.com

*Copyright © 2013 by Electronic Design for Industry
Updated 2013-06-10*